

<http://www.EmbeddedDataSystems.com>

FEATURES

- Wireless communication over the widely accepted 2.4 GHz frequency band
- Highly accurate Temperature, Humidity and Barometric Pressure sensors
- Calculates dew point, humidex, and heat index
- Discrete Input with Activity Latch and 32 bit pulse counter
- Optional Latching Relay may be controlled independently or by alarm status
- Programmable parameters such as send period and alarms
- Globally unique 64-Bit EUI (Extended Unique Identifier)
- Mesh network topology, which essentially enlarges the wireless network and provides additional transmission routes for the sensor data
- Transmission strength reported on all devices, allowing troubled areas to be identified and addressed proactively (e.g. adding Repeaters)
- Robust Communication protocol includes acknowledgements and retries
- Energy efficient design optimizes battery life
- Applications include thermostatic controls, industrial systems, consumer products, thermometers, or any temperature/humidity/light/barometric pressure sensitive system
- Auto adjusts to comply with EU & USA/CA controllers
- *Complies with FCC, Industry Canada and CE Marking requirements*



DESCRIPTION

The EDS **Environmental Sensor Line**, MN-ENV, offers an innovative way to easily *monitor and control* temperature, humidity, barometric pressure, and/or light in indoor environments. The wall mount sensor features high accuracy temperature, humidity, and barometric pressure sensors. The product also contains a light sensor, a discrete input, an LED, and an optional relay. Together these features offer an efficient and flexible system for monitoring the temperature, humidity, barometric pressure, and light levels and a discrete point at one or more locations within a building.

The internal alarm function allows the Environmental Sensor to identify the alarm status of numerous parameters. Upon alarm, the Sensor will immediately transmit while the LED and/or optional Latching Relay can be configured to react to alarm status. Possible alarm configurations include:

- Activate when an alarm parameter is met and deactivate when the alarm byte is cleared
- Activate when an alarm parameter is met and deactivate when readings return to normal range
- Controlled independent of alarm status.

Since, the EDS Environmental Sensor line's alarm functions can operate independently of the controller the sensor may be used as a standalone thermostat, humidistat, pressurestat and/or light sensor.

Part Numbers:

TEMPERATURE	MN-ENV-T
TEMPERATURE/RELAY	MN-ENV-TR
TEMPERATURE/HUMIDITY	MN-ENV-TH
TEMPERATURE/HUMIDITY/RELAY	MN-ENV-THR
TEMPERATURE/LIGHT	MN-ENV-TL
TEMPERATURE/LIGHT/RELAY	MN-ENV-TLR
TEMPERATURE/BAROMETRIC PRESSURE	MN-ENV-TP
TEMPERATURE/BAROMETRIC PRESSURE/RELAY	MN-ENV-TPR
TEMPERATURE/HUMIDITY/BAROMETRIC PRESSURE/LIGHT	MN-ENV-THPL
TEMPERATURE/HUMIDITY/BAROMETRIC PRESSURE/LIGHT/RELAY	MN-ENV-THPLR

INSTALLATION INSTRUCTIONS

1. Remove the Lid of Enclosure - Lightly depress against the two small (0.5"x 0.625") vented sections on the sides of the enclosure and pull the rear of the enclosure away from the front.
2. Inside will be a screw, which will later be used to secure the enclosure together. Set the screw aside until required.
3. Insert right angle end of the 3.5mm Link Cable into the 3.5mm jack, located to the left of the battery holder.
(NOTE: The Link Cable has a custom pin-out; this cable must be purchased from Embedded Data Systems)
4. Insert battery into battery holder.
5. Insert the remaining end of the 3.5mm Link Cable into the jack on the face of the MeshNet Controller.
6. Apply Power. The internal 'linking' process takes under 2 seconds; the LED will flash at ½ second rate when complete. If after 5 seconds the LED does not flash at the ½ second rate, repeat the process once again.
7. The LED flashes at the ½ rate, when Power should be removed.
8. Remove the cable from both the Sensor and the Controller.
9. Apply power to both units to verify function.
10. If connections are to be made to the relay or discrete input, remove the battery.
11. Draw the wires through the circular hole in the rear of the enclosure.
12. Mount the rear of the enclosure on the wall using the diagonal slots reserved for the screws. To arrange for the most complete wireless coverage be certain that the + and - symbols on the rear of the enclosure are at the bottom left. This will position the antenna on the radio module in the upper right position.
13. If connections are to be made to the relay or discrete inputs, make connections as described below.
 - a. Strip 1/8" of the wires.
 - b. Securely attach wires to the corresponding screw-down terminals on the terminal block.
 - c. Wiring the discrete input – There are 2 connections to the discrete input, ground and in, which are labeled on the printed circuit board, opposite the 4 connection terminal strip. The input has a threshold of around 0.8 volts between 0 and 1.
 - d. Wiring the Relay – There is 2 connections to the relay, common (C) and normally open (NO), which are labeled on the printed circuit board, near the 4 connection terminal strip. Connect the wires to these 2 terminals, making certain the wires are securely fastened
14. Reinsert the battery.
15. Replace the Lid of the Enclosure.
16. Insert the screw into the single screw hole found in the upper left corner of the enclosure.

Parameter	Typical	Units
Relay Voltage Rating (DC)	220	Volts
Relay Current Rating (DC)	2	Amps
Relay Switching Rating (DC - resistive load)	30	Watts
Relay Voltage Rating (AC)	250	Volts
Relay Current Rating (AC)	2	Amps
Relay Switching Rating (AC - resistive load)	62.5	VA

SYSTEM DESCRIPTION

The MeshNet Environmental Sensor is part of the MeshNet Wireless Sensor System, designed to monitor and control real world environmental conditions wirelessly. The system is completed with the Embedded Data Systems MeshNet Controller (MN-CTRL). The controller communicates directly with the Environmental Sensor and presents all data via Ethernet. The Sensor and Controller communicate with each other using a proprietary protocol and are not compatible with other wireless networks. An optional system component is Embedded Data Systems' MeshNet Repeater (MN-RPT) which is used to extend the range of communication between the Controller and Environmental Sensor.

Controller: Each wireless system contains a MeshNet Controller. The Controller interfaces the wireless system to a local area network (LAN) or the Internet via Ethernet. It manages, reads/writes to the wireless devices, presents the data in easy to use formats such as HTTP and XML, and optionally pushes the data on a timed basis to a HTTP Post server.

Repeater: Repeaters are used to extend the distance a Sensor can be located from the Controller. Many Sensors can communicate with the Controller through a single Repeater. Each Controller can manage up to 7 Repeaters, and there can be 1 Repeater between a Controller and Sensor.

Sensor: The MeshNet Environmental Sensors provide the means to monitor and control real world environmental conditions. They are typically battery-powered devices that wake on a timed basis, take readings, send the readings to the controller, confirm successful transmission and check to see if any data is waiting for them.

OPERATION

All data from the MeshNet Environmental Sensor is read using a MeshNet Controller. This can be done through HTTP or SNMP, and an option is provided for pushing the data to a HTTP Post server. All data that is retrieved from the Controller programmatically is in XML form. *See the MeshNet Controller Users Manual for more information.*

Temperature

Last reading, displayed in °C.

Humidity

Last reading, displayed in percent.

Dew Point

Last calculation, displayed in °C. This calculation is made after every temperature and humidity reading.

Humidex

Last calculation, displayed in °C. This calculation is made after every temperature and humidity reading.

Heat Index

Last calculation, displayed in °C. This calculation is made after every temperature and humidity reading.

Barometric Pressure

Last reading, displayed in millibars.

Light

Last reading, displayed in Lux.

Battery

Displays voltage of the battery. **NOTE: In order to conserve power, the battery voltage is read only every 10th time.**

LED

Last read state of the LED; 1 indicates LED is on.

Relay

Last read state of the relay; 1 indicates Relay is on.

Input 1

Input 1 provides a means of reading a discrete state; this parameter displays the most recent input state.

Activity Latch 1

Changes in the input state are detected by hardware, even when the sensor is sleeping. An Activity Latch State of 1 indicates the state has changed at least once since it was last reset. Sending the Activity Latch reset command will reset the Activity Latch. See *Discrete Input* for more details on using this input.

Pulse Counter 1

Changes in the input state are detected by hardware, even when the sensor is sleeping. Counts rising edges at Input 1. This is a 32-bit counter that cannot be reset. It is stored in volatile memory, if power is cycled, the number will return to zero. **NOTE: Due to hardware limitations, the first pulse after reset is not counted.**

Input Send

If INPUT SEND is set to 0, input changes are sent every time the sensor wakes up to send other sensor information. If set to 1, all sensor data is sent every time the input changes state (rising or falling edge) or a timed transmission is due. Sending data based on input change causes the timed send to restart. For example, if the device is programmed to send data every minute, but the input changed after 20 seconds and Input Send is set to 1, then the data will be send immediately. Then, a minute later the timed send will occur (assuming the input did not change state during that minute).

LED Function and LED State

The LED may operate in any of the following modes:

Mode	Function
On with any alarm, off if no alarms active*	0
On with any alarm, off when clear alarms command received	1
On and Off under command using State parameter	2
Always off	3

* Mode 0 uses hysteresis to avoid rapid changes in the LED and/or relay. The parameter is in alarm when it is greater than the high alarm value (for the high alarm) or less than the low alarm value (for the low alarm). It is out of alarm when it is less (high alarm) than or greater than (low alarm) the threshold value plus:

Temperature - 1 degrees C

Humidity - 1 %

Dew Point - 1 degrees C

Humidex - 1 degrees C

Heat Index - 1 degrees C

BP – 1 millibar

Light - 1 lux

Battery - 0.1v

The state of the LED is stored in non-volatile memory and restored at power-up.

Relay Function and Relay State

The relay and LED may operate in any of the following modes:

Mode	Function
On with any alarm, off if no alarms active*	0
Off with any alarm, on if no alarms active	1
On with any alarm, off when clear alarms command received	2
Off with any alarm, on when clear alarms command received	3
On and Off under command using State parameter	4
Always off	5
Always on	6

* Hysteresis is applied as described above under LED Function

The relay is a latching relay. It retains state when power is lost. **NOTE: Relay will change state if unit is jolted sufficiently.**

The state of the relay is stored in non-volatile memory and is restored at power-up. Since the relay is latching, its state remains the same, even when power is removed.

ALARM PARAMETERS

Alarms are calculated every time a reading is taken by the sensor, which is programmed using the *sensor read period* parameter. If the reading is above the high alarm value, the corresponding high alarm bit is set, and if the reading is below the low alarm value, the low alarm bit is set.

The primary use for alarms is to cause the LED and/or relay to activate automatically under the desired conditions. See the section above on the LED and relay.

Alarm States

Will set to 1 if an alarm is active. Alarm states can only be cleared by sending the clear alarms command, which clears **all** alarm states; no provision is made to clear individual alarm states.

Alarm Values

Program these values to cause alarms under desired conditions.

	Units	Range	Resolution	High Default	Low Default
Temperature	Centigrade	-40 to 150	1	125	-40
Dew point	Centigrade	-40 to 150	1	125	-40
Humidex	Centigrade	-40 to 150	1	125	-40
Heat index	Centigrade	-40 to 150	1	125	-40
Humidity	Percent	0 to 100	1	100	0
Barometric pressure	Millibars	0 to 2000	0.001	2000.000	0.000
Light	Lux	0 to 500000	1	100000	0
Battery	Volts	0 to 4	0.01	-	2.90

OPERATIONAL PARAMETERS

EUI

The EUI, or Extended Unique Identifier, is a globally unique 64-bit number, represented by 16 hexadecimal digits. This number can be used by software to uniquely identify every MeshNet wireless device.

Controller RSSI

This indicates the strength of the radio signal at the Controller; higher numbers equate to stronger signals. Due to hardware limitations, the highest number that can be displayed is -34 dBm., however the actual signal strength may be much higher.

Device RSSI

This indicates the strength of the radio signal at the Repeater. Due to hardware limitations, the highest number that can be displayed is -34 dBm, however the actual signal strength may be much higher.

Address

This is the address of the repeater, which was assigned by the controller.

Repeater

When the repeater joins the controller, it is assigned a repeater number, which is displayed here. A zero indicates there is no repeater in the communication path.

Health

This is a number ranging from 0 to 7; 0 is not connected and 7 is healthy. The number is incremented when a packet is received from the repeater, and decremented when a packet is not received after a predetermined period of time. Numbers less than 7 indicate a weak wireless link or other problem.

Version

This indicates the firmware version of the sensor.

User Name

The user programmable string used to identify any given Sensor; it may be up to 29 characters long. It is saved in non-volatile memory and so is retained even when power is cycled. The string is best used as a human readable label, which can uniquely identify each MeshNet Environmental Sensor.

Read Counter

Counts the number of times a packet has been sent to the controller. This number has a maximum of 4294967296. When the maximum is reached, the number rolls back to 0 and begins counting up again.

Sensor Read Period

Use to define frequency of sensor readings. Larger periods will conserve battery power. After sensors are read, alarms are checked. If any are found active on this read cycle, they will be sent to the MeshNet Controller immediately.

Each count represents 10 seconds. Maximum number may be 65535. Note that the timer used has a specification of $\pm 15\%$ and is temperature dependent, so there can be a rather large variance between what is programmed and the actual period.

At power up, the device sends data packets every 10 seconds for the first 6 packets, if the read period is not 0. After the first 6 packets are sent, the device reverts to sending packets at the sensor read period duration. This is to facilitate programming in cases where a long read period is desired. Even with very long read periods, simply cycling the power will cause parameters to be written without having to wait for the sensor read period to time out.

Setting	Period
0	4 seconds
1	10 seconds
2	20 seconds
6	1 minute
60	10 minutes
360	1 hour
720	2 hours
8640	1 day
65535	7 days, 14 hours, 2 minutes, 30 seconds

Report Count

Number of sensor read periods to elapse before sending a report to the MeshNet Controller. Zero means send report every time sensors are read.

Setting	Period
0	Send every time the sensors are read
1	Send every other time the sensors are read
2	Send every 2 nd time the sensors are read
3	Send every 3 rd time the sensors are read

Factory Reset

Write anything to this location to reset parameters to factory defaults. The sensor read counter must be below 20 or the command is ignored. This parameter is not sent from the sensor to the controller so no data is presented.

WRITE PARAMETERS

In order to conserve power, MeshNet sensors sleep when not reading the sensors or sending data. When sleeping, they cannot receive wireless data. Because of this, writes are queued by the MeshNet Controller and sent when the Sensors are awake.

Writes Pending

The number of writes waiting to be sent to the sensor.

Writes Succeeded

The number of writes that have been receive and acknowledged by the sensor.

Writes Failed

The number of writes that were not able to be sent to the sensor or were not acknowledged.

WIRELESS COMMUNICATIONS

The device communicates via an industry standard 802.15.4 wireless link. Wireless packets are acknowledged, all data is checked for errors using CRC and corrupted data is resent.

DIAGNOSTIC PARAMETERS

The following parameters are provided for diagnostic purposes. Wireless communications are acknowledged and retried if no acknowledgment is received. The parameters below can be used to determine link quality.

Connection Counter

Counts the number of connections to the controller. When a device is first powered, it connects to a controller, obtaining an address and thus belonging to the network. If the signal strength is good, and power is not lost at the controller, this number will stay low. A high number could be due to low signal strength, periodic interference or power problems. Maximum is 65535, after which the number rolls over to zero and continues to count up.

Message Attempts

The number of times a packet has been sent. This number is the same as Send Counter, except that it can be reset and has a maximum of 65535, after which it rolls over to zero and continues to count up.

Message Packet Retries

The number of times a packet had to be resent due to no acknowledgment being received. Maximum is 65535, after which it rolls over to zero and continues to count up.

Message Failures

When no acknowledgment is received, the packet is resent. After 4 retries, the message has failed. The counter increments when such a failure has occurred. Maximum is 65535, after which it rolls over to zero and continues to count up.

Message Counter Reset

Used to reset the above 3 message counters to zero.

PROGRAMMABLE PARAMETER SUMMARY

	Units	Range	Resolution	High Default	Low Default
Temperature	Centigrade	-40 to 150	1	125	-40
Dew point	Centigrade	-40 to 150	1	125	-40
Humidex	Centigrade	-40 to 150	1	125	-40
Heat index	Centigrade	-40 to 150	1	125	-40
Humidity	Percent	0 to 100	1	100	0
Barometric pressure	Millibars	0 to 2000	0.001	2000.000	0.000
Light	Lux	0 to 500000	1	100000	0
Battery	Volts	0 to 4	0.01	-	2.90
Report count		0 to 65535	1	0	
Sensor read period		0 to 65535	1	0	
LED function		0 to 3	1	2	
Relay function		0 to 6	1	2	
LED state		0 to 1	1	0	
Relay state		0 to 1	1	0	
Input send		0 to 1	1	0	

BATTERY LIFE

The MeshNet Environmental Sensor spends most of its time in sleep mode; it wakes up to take readings, send data and see if any packets are in the queue to be received. Battery life can be maximized by reading the sensors and sending the data as infrequently as possible. The programming parameters *Sensor Read Period* and *Report Count* define how often data is sent to the controller.

Battery life is highly variable on a number of parameters.

1. How often data is sent.
2. How often the sensors are read.
3. Extreme temperatures reduce the useful life of the battery.
4. The number of sensors reduces battery life; barometric pressure and light take relatively little power. Humidity takes the most power, followed by temperature.
5. Battery life is reduced if the relay is switched often or the LED is turned on. The LED is the single largest user of power, far exceeding all other operations.
6. The device can be programmed to read the sensors more often than sending the results. If an alarm is generated, the results will be sent when the alarm is discovered, even if a send is not scheduled. This enables the reduction of the number of wireless transmissions and maximizes battery life without sacrificing responsiveness.
7. If the sensor is sending data through a repeater, battery life will be reduced because the sensor has to wait longer for the acknowledgment.
8. If the sensor has to reconnect to the controller frequently, battery life will be reduced. This happens when the signal is low or there is interference.

LINKING PROCEDURE

1. **Link a MeshNet Sensor to the MeshNet Controller.** Using the custom "Linking Cable" provided, insert the straight 3.5mm connector end into the jack located on the front of the MeshNet Controller. Insert the right angle 3.5mm connector into the jack located inside the MeshNet Sensor (or Repeater). (*Use only the custom "Linking Cable" provided by EDS or linking will not occur.*) If power is not already applied to all devices, do so now. The internal "linking" process takes under 2 seconds; the LED on the face of the MeshNet Sensor will flash at a 1/2 second rate when complete. Once the LED signals success, power and the "Linking Cable" should be removed. (If after 5 seconds the LED does not flash at the 1/2 second rate, repeat the process)
2. **Apply power to the MeshNet Controller a second time.** The green PWR/ACT LED located on the front of the Controller will begin to flash at one-second intervals, indicating that the product is operating normally. Power must be 5 volts +/- 10% at 400 milliamp.



3. **Connect it to your Network.** Connect a live network cable to the Ethernet Port on the device. The green LED on the Ethernet connector will light, indicating a valid network connection. The yellow LED on the Ethernet connector blinks only when there is network traffic.
4. **Determine the IP address of the MeshNet Controller** by checking your DHCP server logs or using EDS Appliance Scanner Software [available](#) from the EDS website. If the MeshNet Controller does not find a DHCP server running on your network, it will default to the following IP address: 169.254.1.1.
5. **Configure your device.** Type the IP address of the MeshNet Controller into your web browser (e.g., <http://192.168.1.27>) and press enter. Select the menu item "Network" under "System Configuration". When the name and password is requested, enter "admin" for the name and "eds" for the password. A webpage similar to the one shown to the right will enable you to configure and monitor various aspects of your MeshNet Controller.

CONGRATULATIONS! You have successfully installed a MeshNet Wireless Sensor System. *Please refer to the Web Access section of the Operation Manual to obtain an understanding of the function of each of the web pages served by the MeshNet Controller.*

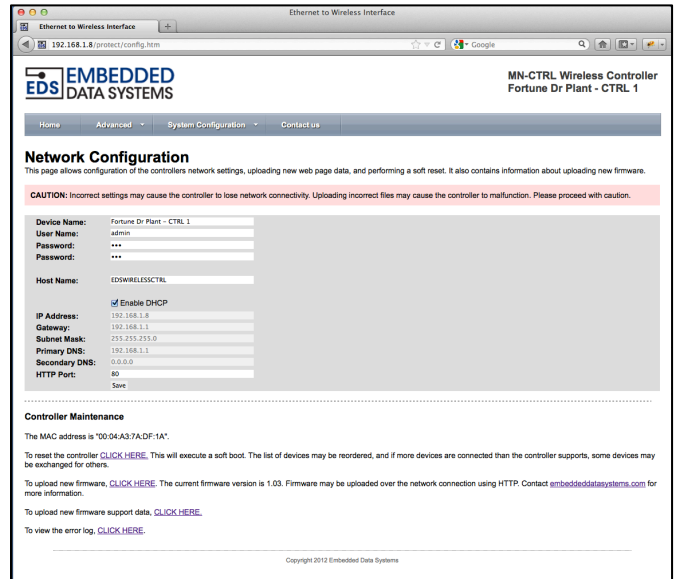

Some things to keep in mind:

- Support is provided for MeshNet Controller IP address identification only when utilizing the EDS Appliance Scanner Software (<http://short.eds.bz/apps-edsscanner>). Please consult your network administrator if you cannot locate the DHCP address.
- **For instructions on appropriate placement of the components of the MeshNet Wireless Sensor System, please refer to Proper Placement section of the Operation Manual.**

EDS ENVIRONMENTAL SENSOR IDS

ID	Features
EDS1064	Temp
EDS1065	Temp, humidity
EDS1066	Temp, barometric pressure
EDS1067	Temp, light
EDS1068	Temp, humidity, barometric pressure and light

EDS REPEATER DEVICE IDS

ID	Features
EDS2101	MeshNet Repeater with high power radio

SPECIFICATIONS

PARAMETER	MIN	TYP	MAX	UNITS
Operating Temperature Range	-40	-	85	°C
Temperature Accuracy -20 to +100°C	-0.5	±0.25	+0.5	°C
Temperature Accuracy -40 to +125°C	-1	±0.25	+1	°C
Temperature Accuracy at 25°C	-0.2	-	0.2	°C
Temperature Resolution	-	0.0625	-	°C
RH Accuracy: 11% RH to 89% RH (note 2)	-5	-	+5	% RH
RH Accuracy: 0-10% RH and 90-100% RH	-7	-	+7	% RH
Pressure Accuracy: 700 to 1,100 hPa at 0 to 65°C (note 2)	-2.5	±1	+2.5	hPa/Millibar
Pressure Accuracy: 300 to 700 hPa at 0 to 65°C	-3	±1	+3	hPa/Millibar
Pressure Accuracy: at -20 to 0°C	-4	±1.5	+4	hPa/Millibar
Pressure Accuracy: 20.67 to 32.48	-0.07	±0.03	+0.07	inHg
Measurement Range	300	-	1,100	hPa/Millibar
Maximum Pressure	-	-	10,000	hPa/Millibar
Light Measurement Range	0	-	65535	Lux
Light Sensitivity	-20	-	+20	%
Relay Voltage Rating (DC)	-	220	-	Volts
Relay Current Rating (DC)	-	2	-	Amps
Relay Switching Power Rating (DC, resistive load)	-	-	30	Watts
Relay Voltage Rating (AC)	-	250	-	Volts
Relay Current Rating (AC)	-	2	-	Amps
Relay Switching Power Rating (AC, resistive load)	-	-	62.5	VA
Supply Voltage	2.9	-	3.6	Volts
Active Current	-	28	-	mA
Sleep Current	-	8.8	-	uA
Battery voltage reading accuracy (note 1)	-1.2	-	+1.2	%
Discrete input voltage	-48	-	+48	Volts
Discrete input low threshold (note 3)	0.435	-	0.54	Volts
Discrete input high threshold (note 3)	1.525	-	1.7	Volts
Pulse counting frequency	-	-	TBD	KHz
Enclosure Dimensions (L x W x H)	80	80	21	mm

Notes:

1. The battery voltage varies depending on how much current is flowing. When the sensor is sleeping, the voltage is higher than when it is awake. The reading is taken when the sensor is awake.
2. These sensors are light sensitive, they should be kept away from bright light or their accuracy will degrade.
3. Discrete input voltages are ratiometric, based on the battery voltage. The input low voltage maximum equation is $0.15 * V_{bat}$, the input high voltage minimum equation is $0.25 * V_{bat} + 0.8$.

Discrete Input

The discrete input circuit can have additional components to suit the intended application. If it is used to monitor contact closure, then it may require a pull up or pull down resistor and capacitor to remove contact bounce. If it is used to count pulses (such as from a flow meter) a capacitor may not be required to remove contact bounce, or if one is required, the value can be modified so the pulses are still present at maximum frequency.

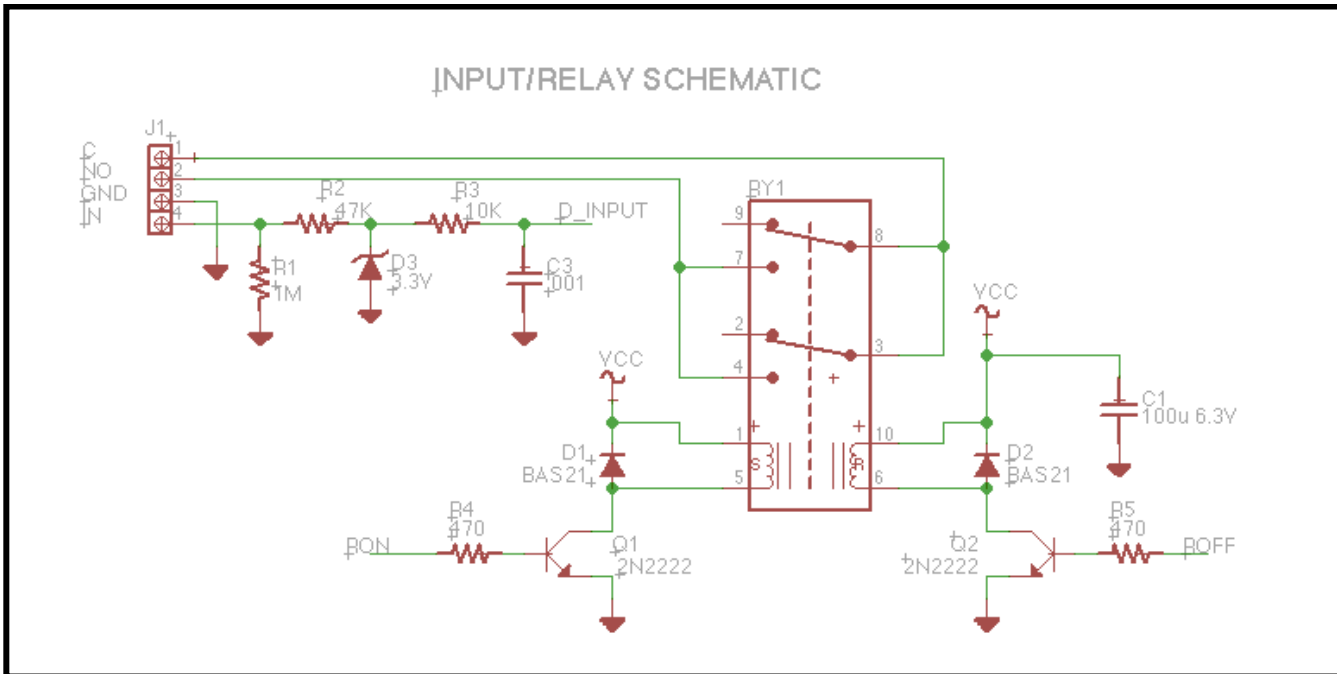

Regulatory Compliance

FEDERAL COMMUNICATIONS COMMISSION (FCC) COMPLIANCE STATEMENT

This device complies with part 15 of the FCC Rules. Operation is subject to the following two conditions: (1) This device may not cause harmful interference, and (2) this device must accept any interference received, including interference that may cause undesired operation.

INDUSTRY CANADA (IC) COMPLIANCE STATEMENT

This Class B digital apparatus complies with Canadian ICES-003.
Cet appareil numérique de la classe B est conforme à la norme NMB-003 du Canada.

EUROPEAN COMMUNITY (EC) DIRECTIVES CONFORMITY

APPLICATION OF COUNCIL DIRECTIVE 2004/108/EC Standard to which Conformity is Declared:

EN 61326-1:2006	(Emissions)
EN 61326-2-3:2006	(Immunity)
EN 61000-3-2:2006+A1:2009+A2:2009	(Harmonics)
EN 61000-3-3:2008	(Flicker)



Caution: *The manufacturer is not responsible for any radio or television interference caused by using other than recommended cables or by unauthorized changes or modifications to this equipment. Unauthorized changes or modifications could void the user's authority to operate this equipment.*